



Installation and Operating Instructions

**Model: HX-2-2NF-INDUCT
HX-2-6NF-INDUCT
HX-2-9NF-INDUCT**



For your convenience, we recommend to attach
the serial number label [HERE](#).

As part of Parmco Appliances commitment to improving and updating product ranges, we reserve the right to alter, change and update technical specifications and appearance attributes of all Parmco Appliances products. E&OE



p: 09 573 5678
 f: 09 573 5699
 e: sales@parmco.co.nz
 w: www.parmco.co.nz



Parmco Appliances extended 7 year warranty

The Warranty:

- This appliance is intended for domestic use in the owners' home. Use of the appliance for commercial purposes will limit the warranty period (please see Parmco website for commercial details).
- Subject to the terms and conditions contained within this warranty, if the product is not of Acceptable Quality (as defined in the Consumer Guarantees Act) within 7 years of the date of original purchase, then Parmco Sales undertakes to repair or, at its sole discretion, replace the product.
- The warranty does not cover the costs of transport, mileage or travelling time if the product is located beyond 30km of a recognised Service Agent.
- This warranty is offered as an extra benefit, and does not affect other legal rights, which can not be modified or excluded by agreement.
- This warranty only applies to goods supplied and installed in the North and South Islands of New Zealand.
- The provisions of this warranty are in addition to the rights and remedies available to consumers under the Consumer Guarantees Act 1993.

Product _____ Date of purchase _____
 Serial Number _____
 Dealer / Retailers Name _____

Please retain this Warranty card together with receipt or other proof of purchase date when seeking service during the warranty period

Please contact Parmco at 09 573 5678 if your appliance needs servicing under warranty. Please have your model number and proof of purchase ready. Warranty repairs must be authorized by Parmco.



The Warranty is not valid:

- If the product is not installed and operated in accordance with the operating instructions.
- If the product is not installed to comply with the electrical, gas, plumbing and other Regulations and Codes of Practice in New Zealand.
- If the product is operated on voltages or frequencies outside the normal range for domestic appliances in New Zealand.
- If the product is not used in normal domestic use, or if it is used in a business as defined in the Consumer Guarantees Act.
- If any serial number has been removed or defaced.
- If proof of date of purchase is not supplied, except at the sole discretion of Parmco Sales. Proof of purchase can be for the product itself, or if installed with a kitchen or house then proof of purchase can be from a Parmco reseller of products supplied by Parmco.
- If the products are purchased in a second hand condition from other parties (including but not limited to TradeMe, Sella, etc.)

Liability under this warranty will not be accepted for:

- Wear and tear caused by normal domestic use of the product.
- Damage in transport.
- Damage caused to the product by neglect, abuse, negligence, wilful act or misuse.
- Any costs associated with the repair, replacement, removal or reinstallation of products installed in a damaged condition.
- Any defect caused by accident, misuse, neglect, tampering with or unauthorised modifications of the appliance or any attempt at internal adjustment or repair by any person other than an Authorised Service Agent.
- Service calls that relate principally to the following:
 - Instruction on how to use the product.
 - Repair or replacement of house fuses, electrical wiring, gas fitting or plumbing.
 - Normal or scheduled maintenance including blocked filters or ducting.
 - Consumable items such as light bulbs.
 - Any damage to hobs caused by spills when cooking.
 - Any breakage or damage of glass items.
 - Any damage caused by non recommended product used for cleaning, maintaining, lubricating or similar.
 - Any aspect relating to the installation of the product, or damage caused during installation including blocked access for repair.
 - Any third party (including reseller) or consequential loss or damage (direct or indirect) however arising.



PARMCO

Dear Valued Customer,

Thank you and congratulations on purchasing your new Parmco appliance.

All Parmco products are made to the highest quality and design standards. We are sure you will enjoy your new appliance.

As a note, please read through these instructions carefully. These will assist you in gaining a complete understanding of the functions and features offered by your appliance. Please take special note of all detailed technical information and installation instructions. It is essential that you follow these instructions to ensure the safety and reliability of this appliance.

Furthermore, not using appropriate personnel to install this appliance may affect any future warranty claims lodged, so please check with Parmco Appliances before any installation is carried out.

We hope you enjoy your new appliance. If you would like to find out more about this product or any other products in Parmco's extensive range, visit us online at www.parmco.co.nz.

Regards,

The Parmco Team

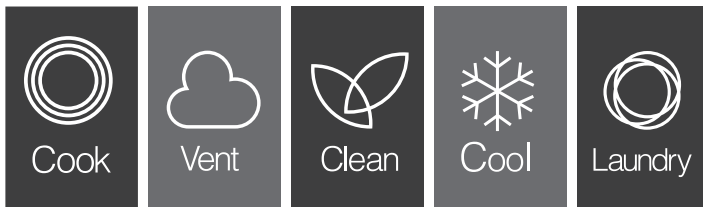

INDEX

| | |
|--|--------------|
| Important Safety Warnings | 2 |
| Product overview | 4 |
| Top view | 4-5 |
| Control panel | 4-5 |
| Induction Cooking | 5 |
| Before using your Induction Hob | 6-7 |
| Using your Induction Hob | 8 |
| To start cooking | 8 |
| When you have finished cooking | 9 |
| Using the boost function | 10 |
| Locking the controls | 11 |
| Using the timer | 11-12 |
| Over-Temperature Protection | 13 |
| Detection of Small Items | 13 |
| Auto Shutdown | 13 |
| Cooking guidelines | 14 |
| Heat settings | 15 |
| Care and cleaning | 16 |
| Troubleshooting | 17 |
| Fault Codes | 18 |
| Technical Specifications | 19 |
| Installation | 20 |

Important Safety Warnings

Your safety is important to us. Please read this information before using your cooktop.

Important safety instructions

- Never leave the appliance unattended when in use. Boil-over causes smoking and greasy spillovers may ignite.
- Never use your appliance as a work or storage surface.
- Never leave any objects or utensils on the appliance.
- No combustible materials are to be placed on the appliance at any time.
- Do not place or leave any magnetised objects (e.g. credit cards, memory cards) or electronic devices (e.g. computers, MP3 players) near the appliance, as they may be affected by its electromagnetic field.
- We recommend using plastic or wooden kitchen utensils for cooking with your induction cooktop.
- Never use your appliance for warming or heating the room.
- After use, always turn off the cooking zones and the cooktop as described in this manual (i.e. by using the touch controls). Do not rely on the pan detection feature to turn off the cooking zones when you remove the pans.
- Do not allow children to play, sit, stand, or climb on the appliance.
- Do not store items of interest to children in cabinets above the appliance. Children climbing on the cooktop could be seriously injured.
- Do not leave children alone or unattended in the area where the appliance is in use.
- Children or persons with a disability which limits their ability to use the appliance should have a responsible and competent person to instruct/supervise them in its use. The instructor should be satisfied that they can use the appliance without danger to themselves or their surroundings.
- Do not repair or replace any part of the appliance unless specifically recommended in the manual. All other servicing should be done by a qualified technician.
- Do not use a steam cleaner to clean your cooktop.
- Do not place or drop heavy objects on your cooktop.
- Do not stand on your cooktop.
- Do not use pans with jagged edges or drag pans across the induction glass surface as this can scratch the glass.
- Do not use scourers or any other harsh abrasive cleaning agents to clean your cooktop, as these can scratch the glass.
- This appliance is intended to be used in a household or similar environments such as staff kitchen areas in shops, offices and other residential environments.
- If the supply cord is damaged, it must be replaced by a special cord or assembly available from the manufacturer or its service agent.
- **WARNING:** The appliance and its accessible parts become hot during use. Care should be taken to avoid touching heating elements.

Children less than 8 years of age should be kept away unless continuously supervised.

- The appliance is not to be used by persons (including children) with reduced physical, sensory or mental capabilities, or lack of experience and knowledge, unless they have been given supervision or instruction children being supervised not to play with the appliance
- **WARNING:** If the surface is cracked, switch off the appliance to avoid the possibility of an electric shock, for hob surfaces of glass-ceramic or similar material which protect live parts.
- The appliance is not intended to be operated by means of an external timer or separate remote-control system.
- **CAUTION:** The cooking process has to be supervised. A short term cooking process has to be supervised continuously.
- **WARNING:** In order to prevent tipping of the appliance, it must be stabilised prior to installation. Please refer to the installation instructions.
- **WARNING:** Use only hob guards designed by the manufacturer of the cooking appliance or indicated by the manufacturer of the appliance in the instructions for use as suitable or hob guards incorporated in the appliance. The use of inappropriate guards can cause accidents.
- This appliance incorporates an earth connection for functional purposes only.
- **WARNING:** Unattended cooking on a hob with fat or oil can be dangerous and may result in fire. NEVER try to extinguish a fire with water, but switch off the appliance and then cover flame e.g. with a lid or a fire blanket.
- **WARNING:** Danger of fire: do not store items on the cooking surfaces.



NOTICE: The crystallite glass is still hot after use, please do not touch!

Installation

Electrical Shock Hazard

- Disconnect the appliance from the main electricity supply before carrying out any work or maintenance on it.
- Connection to a good earth wiring system is essential and mandatory.
- Alterations to the domestic wiring system must only be made by a qualified technician.
- Failure to follow this advice may result in electrical shock or death.

Important safety instructions

- Read these instructions carefully before installing or using this appliance.
- No combustible materials or products should be placed on this appliance at any time.
- Please make this information available to the person responsible for installing the appliance as it could reduce your installation costs.
- In order to avoid a hazard, this appliance must be installed according to these instructions for installation.
- This appliance must be properly installed and earthed by a qualified technician.
- This appliance should be connected to a circuit which incorporates an isolating switch, providing full disconnection from the power supply.
- Failure to install the appliance correctly could void any warranty or liability claims.

Operation and maintenance

Electrical Shock Hazard

- Do not cook on a broken or cracked cooktop. If the cooktop surface break or crack, switch the appliance off immediately at the main power supply (wall switch) and contact a qualified technician.
- Switch the cooktop off at the wall before cleaning or maintenance.
- Failure to follow this advice may result in electrical shock or death.

Health Hazard

- This appliance complies with electromagnetic safety standards.
- However, persons with cardiac pacemakers or other electrical implants (such as insulin pumps) must consult with their doctor or implant manufacturer before using this appliance to make sure that their implants will not be affected by the electromagnetic field.
- Failure to follow this advice may result in death.

Hot Surface Hazard

- During use, accessible parts of this appliance will become hot enough to cause burns.
- Do not let your body, clothing or any other items other than suitable cookware contact the Induction glass until the surface is cool.
- Never leave metal objects (such as kitchen utensils) or empty pans on the cooktop as they can become hot very quickly.
- Beware: magnetisable metal objects worn on the body may become hot in the vicinity of the cooktop. Gold or silver jewellery will not be affected.
- Keep children away.
- Handles of saucepans may be hot to touch. Check saucepan handles do not overhang other cooking zones that are on. Keep handles out of reach of children.
- Failure to follow this advice could result in burns and scalds.

Product Overview

HX-2-2NF-INDUCT

Top View



Control Panel

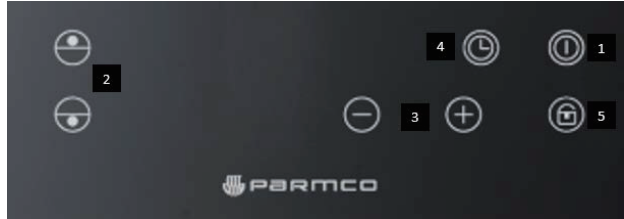

1. ON/OFF control
2. Cooking zone selection controls
3. Heat/Timer Regulation Controls
4. Timer
5. Key/child Lock Controls

HX-2-6NF-INDUCT

Top View



Control Panel



1. ON/OFF control
2. Cooking zone selection controls
3. Heat/Timer Regulation Controls
4. Timer
5. Key/child Lock Controls
6. Boost Control

HX-2-9NF-INDUCT

Top View

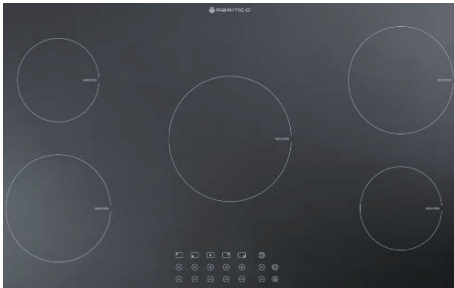

Control Panel

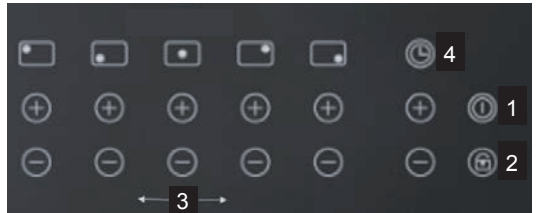

1. ON/OFF control
2. Key/child Lock Controls
3. Heat/Timer Regulation Controls
4. Timer

Induction Cooking

Induction cooking is a safe, advanced, efficient, and economical cooking technology. It works by electromagnetic vibrations generating heat directly in the pan, rather than indirectly through heating the glass surface. The glass becomes hot only because the pan eventually warms it up.

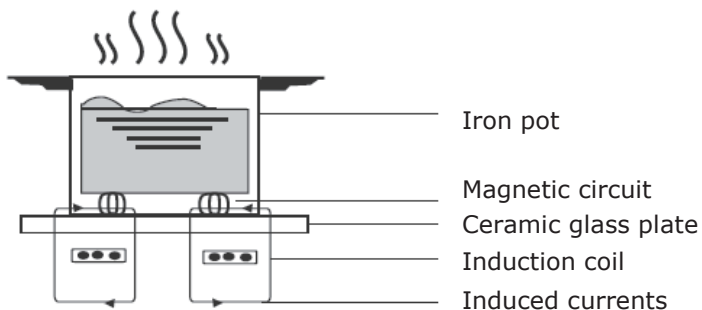

Before using your Induction Hob

- Read this guide, taking special note of the 'Safety Warnings' section.
- Remove any protective film that may still be on your Induction hob.
- BOOST function - when selected the power of the cooking zone increases to 1500W/2000W for 5 minutes only, before reverting to the previous heat setting.

Using the Touch Controls

- The controls respond to touch, so you do not need to apply any pressure.
- Use the ball of your finger, not its tip.
- You will hear a beep each time a touch is registered.
- Make sure the controls are always clean, dry, and that there are no objects (e.g. a utensil or a cloth) covering them. Even a thin film of water may make the controls difficult to operate.

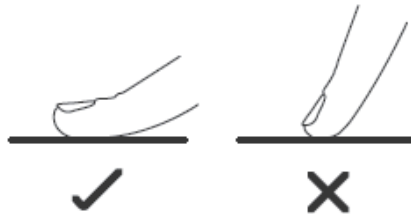

Choosing the right Cookware

- Only use cookware with a base suitable for induction cooking. Look for the induction symbol on the packaging or on the bottom of the pan.
- You can check whether your cookware is suitable by carrying out a magnet test. Move a magnet towards the base of the pan. If it is attracted, the pan is suitable for induction.
- If you do not have a magnet:
 - Put some water in the pan you want to check.
 - Follow the steps under 'To start cooking' on page 7.
 - If  does not flash in the display and the water is heating, the pan is suitable.
- Cookware made from the following materials is **not** suitable: pure stainless steel, aluminum or copper without a magnetic base, glass, wood, porcelain, ceramic, and earthenware.



Do not use cookware with jagged edges or a curved base.



Make sure that the base of your pan is smooth, sits flat against the glass, and is the same size as the cooking zone. Use pans with a base diameter that is as large as the graphic of the zone selected. By using a slightly wider pot, energy will be used at its maximum efficiency. If you use a smaller pot, the efficiency could be less than expected. Pots less than 140 mm could be undetected by the hob. Always centre your pan on the cooking zone.

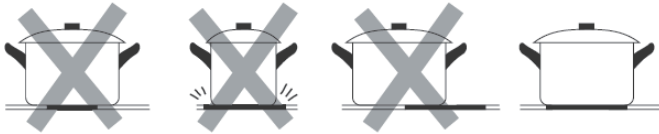

Always lift pans off the Induction hob – do not slide, as they may scratch the glass.

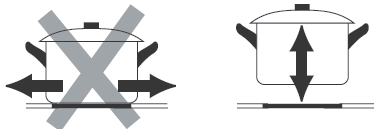

Using your Induction Hob

To start cooking



No heating takes place unless there is a suitable pan on the cooking zone.

The display will automatically turn off after 1 minute, if no suitable pan is placed on it.

1. Place a suitable pan on the cooking zone that you wish to use.

- Make sure the bottom of the pan and the surface of the cooking zone are clean and dry.

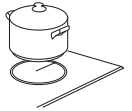

2. Touch the  ON/OFF control

After switching the power on, the buzzer beeps once. All displays show “-” or “--”, indicating that the induction hob has entered standby mode.

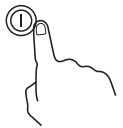

Note: if the display flashes “”, alternatively with the heat setting, this means:

- Pan has not been placed on the correct cooking zone
- Pan is not suitable for induction hob.
- Pan is too small and can not be detected, or not positioned correctly.

3. Touch the cooking zone you wish to use, for the HX-2-6NF-INDUCT and HX-2-2NF-INDUCT. For HX-2-9NF-INDUCT touch “-” or “+” below heating zone symbols, the relative heating zone will flash.



4. Select a heat setting by touching the “-/+” regulating controls or for the HX-2-6NF-INDUCT you can also move your finger along the slider control.

- If you do not choose a heat setting within 1 minute, the Induction hob will automatically switch back to standby mode. You will need to start again at step 1.
- You can modify the heat setting at any time during cooking.



Slider controller can adjust power level only, can't adjust timer function!

When you have finished cooking

1. Touch the cooking zone selection control that you wish to switch off, for the HX-2-6NF-INDUCT and HX-2-2NF-INDUCT.



2. Turn the cooking zone off by scrolling down to "0" using the "-" regulating control.

The display will then show "H"

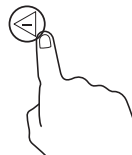

3. Alternatively turn the whole cooktop off by touching the ON/OFF control

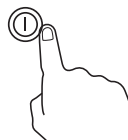

4. Beware of hot surfaces

- "H" will show which cooking zone is still hot to touch. The signal will disappear when the surface has cooled down to a safe temperature. It can also be used as an energy saving function - if you want to heat further pans, use the hotplate that is still hot.

Note: the residual heat indicator will disappear if the main power supply to the hob is turned off.

Using the Boost function for the HX-2-6NF-INDUCT

- The boost function can operate in all cooking zones.
- The cooking zone will return to its original setting after 5 minutes.

Activate the boost function

1. Touch the cooking zone required
2. Touch the boost  control, and “P” will appear in the display.
3. Cooking zone will function at the higher power for 5 minutes only, before reverting the previously selected heat setting.

Cancel the Boost function

1. Touch  the Boost to cancel the boost function.
The cooking zone will revert to the previously selected heating level.

Locking the Controls

You can lock the controls to prevent unintended use (for example children accidentally turning the cooking zones on).

When this function is activated, all controls except the ON/OFF control are disabled.

To lock the controls

1. Touch and hold the  keylock symbol and the timer indicator display will show “Lo”

To unlock the controls

1. Make sure the hob is turned on.
2. Touch and hold the keylock  control to unlock the hob control panel. “Lo will disappear from the display.
3. The hob is now unlocked, and you can now start using it.



When the hob is in lock mode, all controls are disabled except the ON/OFF control. In an emergency, you can turn the induction hob off with the ON/OFF button, but you will have to unlock the hob first before the next use.

Using the Timer

You can use the timer to turn one or more cooking zones off after a set amount of time.

Note: The timer can be set for up to 99 minutes for each cooking zone.

The timer will begin to count down immediately after being set.

Setting the timer to turn one heating zone off

1. For the HX-2-6NF-INDUCT and HX-2-2NF-INDUCT, touch the heating zone control that you want to set the timer for.
For HX-2-9NF-INDUCT touch “-” or “+” below heating zone symbols, that you want to set the timer for.
2. Select the heat level using the “-” or “+” regulating controls
3. Touch the timer control, the display will show “30”

4. Set the time by touching the “-“ or “+” regulating controls.

Hint: Touch the “-“ or “+” controls once and the time will change in increments of 1 minute.

Touch and hold the “-“ or “+” control and the time will change in increments of 10 minutes.

- If the setting time exceeds 99 minutes, the timer will automatically return to 0 minutes.

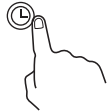

Cancelling the timer for a heating zone

1. Press the “-“ timer regulating key to reduce the time outstanding to 0.

OR

2. Touch the Timer control to cancel the timer.
3. Display will show “00”

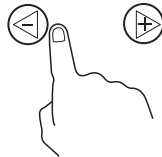

When the selected cooking time has been reached, the corresponding cooking zone will switch off automatically.

Other heating zone will keep operating if it had previously been turned on.

Over-Temperature Protection

A temperature sensor can monitor the temperature inside the Induction hob. When excessive temperature is detected, the Induction hob will stop operation automatically.

Detection of Small Items

When an unsuitable sized/non-magnetic pan, or some other small item (e.g. knife, fork, key) has been left on the hob, the hob automatically goes on to standby after 1 minute. The fan will keep cooling the induction hob for a further 1 minute.

Auto Shutdown

Auto shutdown is a safety protection function for your induction hob. It shuts down automatically if you ever forget to turn off your cooking. The default working times for various power levels are shown in the table below.

| | | | | | | | | | |
|------------------------------|---|---|---|---|---|---|---|---|---|
| Power level | 1 | 2 | 3 | 4 | 5 | 6 | 7 | 8 | 9 |
| Default working timer (hour) | 8 | 8 | 8 | 4 | 4 | 4 | 2 | 2 | 2 |

When the pot is removed, the induction hob will stop heating immediately and the hob will automatically switch off after 1 minutes.



People with a heart pace maker should consult with their doctor before using this unit.

Cooking Guidelines



Take care when frying as oils and fats heat up very quickly, particularly if you are using Power Boost. At extremely high temperatures, oils and fats will ignite spontaneously and present a serious fire risk.

Cooking Tips

- When food comes to boil, reduce the temperature setting.
- Using a lid will reduce cooking times and save energy by retaining the heat.
- Minimise the amount of liquid or fat to reduce cooking times.
- Start cooking on a high temperature setting and reduce the setting when the food has heated through.

Simmering, cooking rice

- Simmering occurs below boiling point at around 85°C when bubbles are just rising occasionally to the surface of the cooking liquid. It is the key to delicious soups and tender stews because the flavours develop without overcooking the food. You should also cook egg-based and flour-thickened sauces below boiling point.

Searing steak

To cook juicy flavoursome steaks:

1. Stand the meat at room temperature for about 20 minutes before cooking.
2. Heat up a heavy-based frying pan.
3. Brush both sides of the steak with oil. Drizzle a small amount of oil into the hot pan and then lower the meat onto the hot pan.
4. Turn the steak only once during cooking. The exact cooking time will depend on the thickness of the steak and how cooked you want it. Times may vary from about 2 – 8 minutes per side. Press the steak to gauge how cooked it is – the firmer it feels the more ‘well done’ it will be.
5. Leave the steak to rest on a warm plate for a few minutes to allow it to relax and become tender before serving.

For stir-frying

1. Choose an induction compatible flat-based wok or a large frying pan.
2. Have all the ingredients and equipment ready. Stir-frying should be quick. If cooking large quantities, cook the food in several smaller batches.
3. Preheat the pan briefly and add two tablespoons of oil.
4. Cook any meat first, then put it aside and keep warm.
5. Stir-fry the vegetables. When they are hot but still crisp, turn the cooking zone to a lower setting, return the meat to the pan and add your sauce.
6. Stir the ingredients gently to make sure they are heated through.
7. Serve immediately.

Heat Settings

The settings below are guidelines only. The exact setting will depend on several factors, including your cookware and the amount you are cooking. Experiment with the induction hob to find the settings that are best suitable for you.

| Heat setting | Suitability |
|--------------|---|
| 1 - 2 | <ul style="list-style-type: none">• delicate warming for small amounts of food• melting chocolate, butter, and foods that burn quickly• gentle simmering• slow warming |
| 3 - 4 | <ul style="list-style-type: none">• reheating• rapid simmering• cooking rice |
| 5 - 6 | <ul style="list-style-type: none">• pancakes |
| 7 - 8 | <ul style="list-style-type: none">• sautéing• cooking pasta |
| 9/P | <ul style="list-style-type: none">• stir-frying• searing• bringing soup to boil• boiling water |

Care and Cleaning

| What? | How? | Important! |
|--|--|---|
| <p>Everyday soiling on glass (fingerprints, marks, stains left by food or non-sugary spillovers on the glass).</p> | <ol style="list-style-type: none"> 1. Switch the power to the cooktop off. 2. Apply a cooktop cleaner while the glass is still warm (but not hot!). 3. Rinse and wipe dry with a clean cloth or paper towel. 4. Switch the power to the cooktop back on. | <ul style="list-style-type: none"> • When the power to the cooktop is switched off, there will be no 'hot surface' indication but the cooking zone may still be hot! Take extreme care. • Heavy-duty scourers, some nylon scourers and harsh/abrasive cleaning agents may scratch the glass. Always read the label to check if your cleaner or scourer is suitable. • Never leave cleaning residue on the cooktop: the glass may become stained. |
| <p>Boilovers, melts, and hot sugary spills on the glass.</p> | <p>Remove these immediately with a fish slice, palette knife or razor blade scraper suitable for Induction glass cooktops, but beware of hot cooking zone surfaces:</p> <ol style="list-style-type: none"> 1. Switch the power to the cooktop off at the wall. 2. Hold the blade or utensil at a 30° angle and scrape the soiling or spill to a cool area of the cooktop. 3. Clean the soiling or spill up with a dish cloth or paper towel. 4. Follow steps 2 to 4 for 'Everyday soiling on glass' above. | <ul style="list-style-type: none"> • Remove stains left by melts and sugary food or spillovers as soon as possible. If left to cool on the glass, they may be difficult to remove or even permanently damage the glass surface. • Cut hazard: when the safety cover is retracted, the blade in a scraper is razor-sharp. Use with extreme care and always store safely and out of reach of children. |
| <p>Spillovers on the touch controls.</p> | <ol style="list-style-type: none"> 1. Switch the power to the cooktop off. 2. Soak up the spill. 3. Wipe the touch control area with a clean damp sponge or cloth. 4. Wipe the area completely dry with a paper towel. 5. Switch the power to the cooktop back on. | <ul style="list-style-type: none"> • The cooktop may beep and turn itself off, and the touch controls may not function while there is liquid on them. Make sure you wipe the touch control area dry before turning the cooktop back on. |

Troubleshooting

| Problem | Possible causes | What to do |
|---|---|--|
| The induction hob cannot be turned on. | No power. | <p>Make sure the induction hob is connected to the power supply and that it is switched on.</p> <p>Check whether there is a power outage in your home or area. If you have checked everything and the problem persists, call a qualified technician.</p> |
| The touch controls are unresponsive. | The controls are locked. | Unlock the controls. See section 'Using your induction cooktop' for instructions. |
| The touch controls are difficult to operate. | There may be a slight film of water over the controls or you may be using the tip of your finger when touching the controls. | Make sure the touch control area is dry and use the ball of your finger when touching the controls. |
| The glass is being scratched. | <p>Rough-edged cookware.</p> <p>Unsuitable, abrasive scourer or cleaning products being used.</p> | <p>Use cookware with flat and smooth bases. See 'Choosing the right cookware'.</p> <p>See 'Care and cleaning'.</p> |
| Some pans make crackling or clicking noises. | This may be caused by the construction of your cookware (layers of different metals vibrating differently). | This is normal for cookware and does not indicate a fault. |
| The induction hob makes a low humming noise when used on a high heat setting. | This is caused by the technology of induction cooking. | This is normal, but the noise should quieten down or disappear completely when you decrease the heat setting. |
| Fan noise coming from the induction hob. | A cooling fan built into your induction hob has turned on to prevent the electronics from overheating. It may continue to run even after you've turned the induction hob off. | This is normal and needs no action. Do not switch the power to the induction hob off at the wall while the fan is running. |
| Pans do not become hot. | <p>The induction hob cannot detect the pan because it is not suitable for induction cooking.</p> <p>The induction hob cannot detect the pan because it is too small for the cooking zone or it is not properly centred on the zone.</p> | <p>Use cookware suitable for induction cooking. See section 'Choosing the right cookware'.</p> <p>Centre the pan and make sure that its base matches the size of the cooking zone.</p> |

| | | |
|---|------------------|--|
| The induction hob or a cooking zone has turned itself off unexpectedly, a tone sounds and an error code is displayed (typically alternating with one or two digits in the cooking timer display). | Technical fault. | Please note down the error letters and numbers, switch the power to the induction hob off at the wall, and contact a qualified technician. |
|---|------------------|--|

Fault Codes

If an abnormality comes up, the induction hob will enter a protective state automatically and display the corresponding protective codes:

| Problem | Possible causes | What to do |
|---------|--|---|
| F3-F4 | Temperature sensor failure of induction coil. | Please contact a technician. |
| F9-FA | Temperature sensor failure of the IGBT. | Please contact a technician. |
| E1/E2 | Abnormal supply voltage. | Please inspect whether power supply is normal. Power on after the power supply is normal. |
| E3 | Abnormally high temperature of induction coil temperature sensor | Please contact a technician. |
| E5 | Abnormally high temperature of IGBT temperature sensor | Please restart after the induction hob cools down. |

The above are the judgment and inspection of common failures.

Please do not disassemble the unit by yourself to avoid any dangers and damages to the induction hob.

Technical Specification

| | | |
|--------------------|-----------|-----------------|
| Cooking Hob | | HX-2-2NF-INDUCT |
| Cooking Zones | | 2 Zones |
| Supply Voltage | | 220-240V~ 50Hz |
| Power | | 2000W (180mm) |
| | | 1500W (140mm) |
| Product Size | L×W×H(mm) | 288x520x63mm |
| Cut Out Dimensions | A×B (mm) | 268x500 mm |

| | | |
|--------------------|-----------|---------------------------|
| Cooking Hob | | HX-2-6NF-INDUCT |
| Cooking Zones | | 4 Zones |
| Supply Voltage | | 220-240V~ 50Hz |
| Power | | 1500W/Boost 2000W (180mm) |
| | | 1200W/Boost1500W (140mm) |
| Product Size | L×W×H(mm) | 590x520x77mm |
| Cut Out Dimensions | A×B (mm) | 560x490mm |

| | | |
|--------------------|-----------|-----------------|
| Cooking Hob | | HX-2-9NF-INDUCT |
| Cooking Zones | | 5 Zones |
| Supply Voltage | | 220-240V~ 50Hz |
| Power | | 2000W (210mm) |
| | | 2000W (180mm) |
| | | 1500W (140mm) |
| Product Size | L×W×H(mm) | 860x520x77mm |
| Cut Out Dimensions | A×B (mm) | 830x490mm |

Dimensions are approximate. Because we continually strive to improve our products we may change specifications and designs without prior notice.

Installation

Dear Installer:

Please affix data label provided on the adjacent cupboard near the appliance for future reference. Thank you.

Selection of installation equipment

- Cut out the work surface according to the sizes shown in the drawing.
- For the purpose of installation and use, a minimum of 50mm space shall be preserved around the hole.
- Be sure the thickness of the work surface is at least 40-50mm. Please select heat-resistant work surface material to avoid larger deformation caused by the heat radiation from the hotplate.
- When installing the hob over drawers, a board must be installed 10mm underneath the hob. The board must be made of suitable heat resistant materials.

Cautions

1. The induction hotplate must be installed by qualified personnel or technicians. Never conduct the installation by yourself.
2. The hob must not be installed directly above a dishwasher, fridge, freezer, washing machine or clothes dryer, as the humidity may damage the hob electronics.
3. The wall and induced heating zone above the tabletop must be able to withstand heat.
4. To avoid any damage, the sandwich layer and adhesive must be resistant to heat.

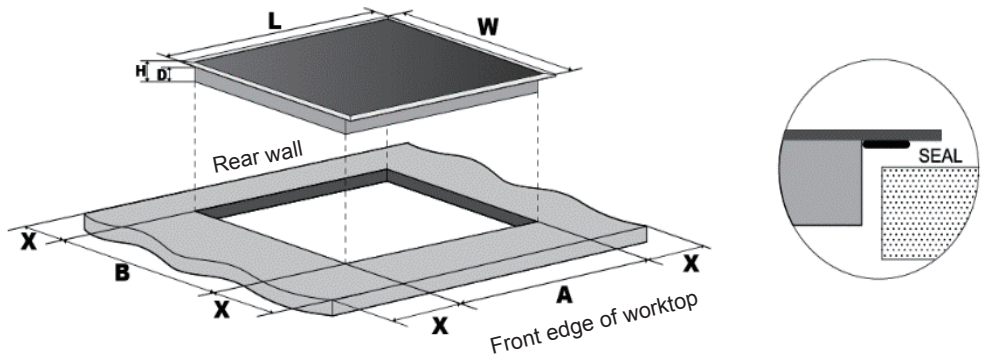

| HX-2-2NF-INDUCT | | | | | | |
|-----------------|-------|-------|-------|-------|-------|--------|
| L(mm) | W(mm) | H(mm) | D(mm) | A(mm) | B(mm) | X(mm) |
| 288 | 520 | 63 | 58 | 268 | 500 | 50 min |
| HX-2-6NF-INDUCT | | | | | | |
| L(mm) | W(mm) | H(mm) | D(mm) | A(mm) | B(mm) | X(mm) |
| 590 | 520 | 77 | 72 | 560 | 490 | 50 min |
| HX-2-9NF-INDUCT | | | | | | |
| L(mm) | W(mm) | H(mm) | D(mm) | A(mm) | B(mm) | X(mm) |
| 860 | 520 | 77 | 72 | 830 | 490 | 50 min |

Under any circumstances, make sure the Induction hob is well ventilated and the air inlet and outlet are not blocked. Ensure the Induction hob is in good working state.



Note: The safety distance between the hob and the extraction system above at least be 650mm.

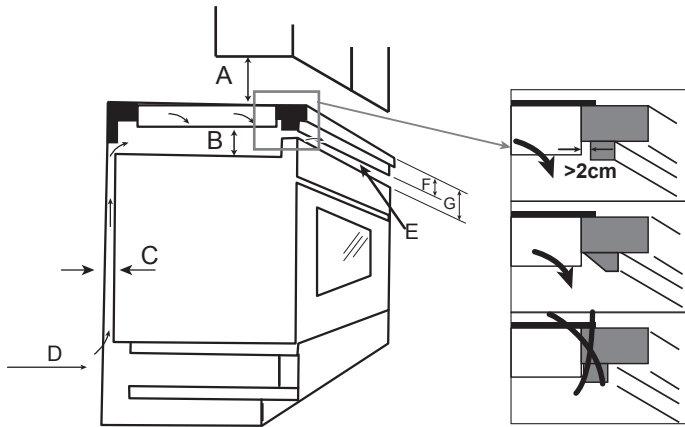

| A(mm) | B(mm) | C(mm) | D | E | F | G |
|-------|--------|--------|------------|----------------------------|----------------|----------------|
| 650 | 50 min | 20 min | Air intake | Air exit $\geq 5\text{mm}$ | $>35\text{mm}$ | $<50\text{mm}$ |

Before you install the hob, make sure that

- the work surface is made of a heat-resistant material.
- if the hob is installed above an oven, the oven has a built-in cooling fan.
- the installation complies with all clearance requirements and New Zealand standards and regulations.
- a suitable isolating switch providing full disconnection from the mains power supply is incorporated in the permanent wiring, mounted and positioned to comply with the local standards and regulations.
- the isolating switch must be of an approved type and provide a 3 mm air gap contact separation in all poles (or in all active [phase] conductors if the local wiring rules allow for this variation of the requirements).
- the isolating switch will be easily accessible to the customer with the hob installed.
- consult local building authorities and by-laws if in doubt regarding installation.
- heat-resistant and easy-to-clean finishes (such as ceramic tiles) are used for the wall surfaces surrounding the hob.
- the power supply cable is not accessible through cupboard doors or drawers.
- there is an adequate flow of fresh air from outside the cabinetry to the base of the hob.
- if the hob is installed above a drawer or cupboard space, a thermal protection barrier is installed below the base of the hob.
- the isolating switch is easily accessible.

Inserting and fixing the hob

Before inserting the hob into the work surface, place the adhesive seal around the underside edge of the hob. It is important to fix the seal evenly without gaps, to prevent liquids from seeping underneath the hob.

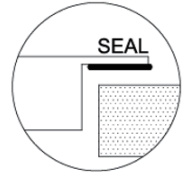

1. Place the gasket around the bottom edge of the hob.
2. Place the hob in the work surface cutout, so the hob is sitting firmly on the surface.
3. Secure the hob to the underside of the work surface using the fixing brackets supplied.

Screw one end of the bracket to the holes on the underside of the hob.

Adjust the position of the brackets to suit the thickness of the work surface.

Secure the other end of the bracket to the underside of the work surface, in order to secure the hob into position.

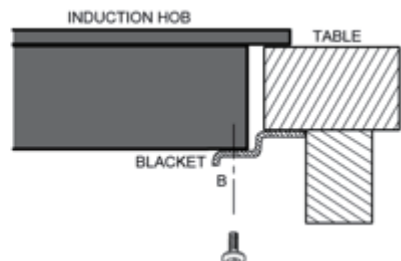
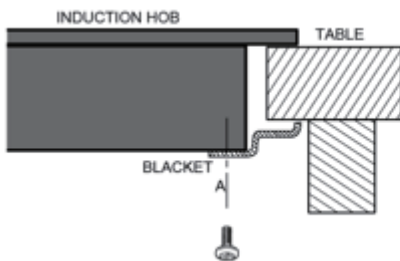
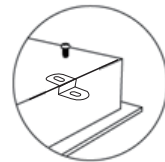
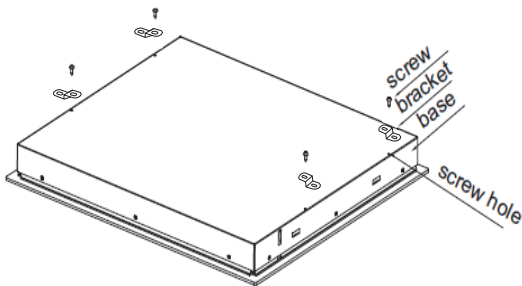

Connecting the hob to the mains power supply



This hob must be connected to the main power supply by a qualified personnel.

Before connecting the hob to the mains power supply, check that:

1. the domestic wiring system is suitable for the power drawn by the hob.
2. the voltage corresponds to the specifications provided in the manual and data label.
3. the power supply cable sections can withstand the load specified on the rating plate.

To connect the hob to the mains power supply, do not use adapters, reducers, or branching devices, as they can cause overheating and fire. The power supply cable must not touch any hot parts and must be positioned so that its temperature will not exceed 75°C at any point.



Check with an electrician whether the domestic wiring system is suitable without alterations. Any alterations must only be made by a qualified technician.

The power supply should be connected in compliance with the relevant local standard.

HX-2-2NF-INDUCT

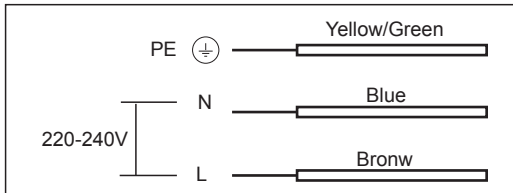

HX-2-6NF-INDUCT

| | | |
|---|--|--|
| <p>CONNECTION DIAGRAM Caution! Voltage of heating elements 220-240V Caution! In the event of any connection the safety Wire must be connected to the \oplus E terminal.</p> | | <p>Recommended type of connection lead</p> |
| <p>For 220-240V earthed one-phase connection, bridges connect L①-② terminals and N④-⑤ terminals, safety wire to \oplus</p> | | |

HX-2-9NF-INDUCT

| | | |
|--|--|--|
| <p>CONNECTION DIAGRAM Caution! Voltage of heating elements 220-240V Caution! In the event of any connection the safety Wire must be connected to the ⊕ E terminal.</p> | | <p>Recommended type of connection lead</p> |
| <p>For 220-240V earthed one-phase connection, bridges connect L ①-②-③ terminals and N ④-⑤ terminals, safety wire to ⊕</p> | | |



WARNING

Close the cable clamp after making the electrical connection. Close the terminal board cover by twisting it down.

TERMINAL BOARD

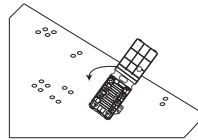

- If the appliance is being connected directly to the mains an omnipolar circuit-breaker must be installed with a minimum opening of 3mm between contacts.
- If the cable is damaged or is to be replaced, the operation must be carried out by a qualified person.
- The installer must ensure that the correct electrical connection has been made and that it is compliant with safety regulations.
- The cable must not be bent or compressed.
- The installer must use the supplied power cord.



DISPOSAL: Do not dispose this product as unsorted municipal waste. Collection of such waste separately for special treatment is necessary.

This appliance is labeled in compliance with European directive 2012/19/EC for Waste Electrical and Electronic Equipment (WEEE). By ensuring that this appliance is disposed of correctly, you will help prevent any possible damage to the environment and to human health, which might otherwise be caused if it were disposed of in the wrong way.

The symbol on the product indicates that it may not be treated as normal household waste. It should be taken to a collection point for the recycling of electrical and electronic goods.

This appliance requires specialist waste disposal. For further information regarding the treatment, recover and recycling of this product please contact your local council or your household waste disposal service.

For more detailed information about treatment, recovery and recycling of this product, please contact your local city office or your household waste disposal service.